

Hazardous Materials Railroad Survey

Montgomery & Greene Counties, Ohio

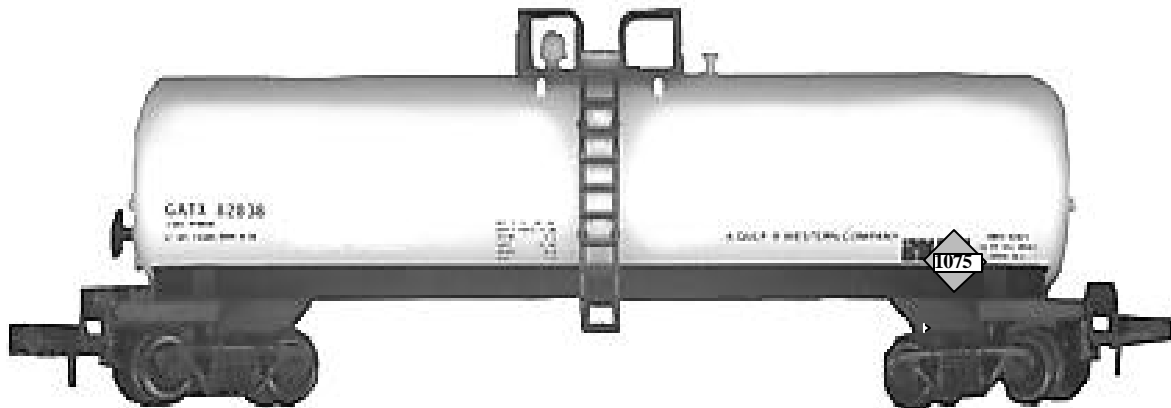

August, 1998

Montgomery/Greene County Local Emergency Response Council

Prepared By: Miami Valley Regional Planning Commission

40 West Fourth Centre, Suite 400, Dayton, OH 45402 (937)223-6323

TABLE OF CONTENTS

	Page
INTRODUCTION	1
PLACARD REQUIREMENTS	1
METHOD OF SURVEY	2
RESULTS BY RAILROAD CAR TYPE	4
RESULTS BY SURVEY DATE	4
RESULTS BY TIME-OF-DAY	4
RESULTS BY TYPE OF PLACARD	7
RESULTS BY RAILROAD	7
MOST FREQUENTLY OBSERVED PLACARD TYPES	9
EXTREMELY HAZARDOUS SUBSTANCES (EHS) PLACARDS	10
SUMMARY	14
APPENDIX A - PLACARD OBSERVATIONS BY TRAIN - FULL DATA TABLE	
APPENDIX B - KEY TO OBSERVED PLACARDS	

LIST OF MAPS

Map 1	Location of Haz/Mat Railroad Survey Point - Greene & Montgomery Counties	3
-------	--	---

LIST OF TABLES

Table 1 Summary of Railroad Haz/Mat Survey By Survey Date	5
Table 2 Summary of Railroad Haz/Mat Survey By Time-of-Day	6
Table 3 Observation Frequency of Placard Types	7
Table 4 Summary of Railroad Haz/Mat Survey By Railroad	8
Table 5 Ten Most Frequently Observed Placard IDs	11
Table 6 Extremely Hazardous Substances Observed	12

INTRODUCTION

As a result of the completion of the interstate highway network and improvements to other nationally and regionally important highways, rail has lost much of its competitive advantage to trucking. However, freight movement by railroad is still an important part of keeping the national economy in good working order. Railroads provide an efficient means of transporting heavy goods and bulk loads, including hazardous materials.

Many hazardous materials are shipped by rail. The fact that railroad accidents involving hazardous materials can and do occur was illustrated most dramatically by the 1986 train derailment in Miamisburg, when about 5,000 gallons of phosphorus was spilled along with animal fat and molten sulfur. To protect public safety and health, evacuations involving 30,000 people were involved. This study is a beginning step toward gaining a better understanding of the type and frequency of hazardous material shipments being transported by rail within Montgomery and Greene Counties.

The Montgomery/Greene County Local Emergency Response Council (MGCLERC) is responsible for hazardous materials emergency response planning within Montgomery and Greene Counties. The Miami Valley Regional Planning Commission (MVRPC) is the metropolitan planning organization (MPO) responsible for overall transportation planning within Montgomery, Greene, and Miami Counties, including monitoring various types of freight movements. This study was undertaken by MVRPC with the assistance of the Miami Valley Emergency Management Authority (MVEMA) for MGCLERC with the aid of a grant from the Hazardous Materials Transportation Act (HMTA) to the MGCLERC.

PLACARD REQUIREMENTS

The Hazardous Materials Regulations of the U.S. Department of Transportation (49CFR Pt. 172 - Subpart F) require placarding of rail cars and multi-modal containers on flatcars carrying hazardous materials. Hazardous materials must be identified on shipping papers regardless of the quantity shipped. Rail cars must be marked on front, rear, and both sides with the appropriate placards. The placards must bear the appropriate four-digit ID number assigned by the Research and Special Programs Administration of the Department of Transportation, and be designed to stated sizing, coloring and placement standards.

Rail cars carrying explosives, extremely toxic materials, materials that are dangerous when wet, and high-strength radioactives in any amount must be placarded. Placards are not required on rail cars containing 1,000 pounds (454 kg) or less aggregate gross weight of other hazardous materials. Rail cars carrying highly toxic, flammable and oxidizing materials, corrosive liquids, and both flammable and non-flammable compressed gases in quantities exceeding 1,000 pounds are considered bulk shipments and must be placarded. Placards displayed on truck trailers or freight containers on flatcars may be used to satisfy the placarding requirement.

A rail car carrying two or more categories of hazardous materials each totaling 1,000 pounds or less, but together totaling more than 1,000 pounds requires a “**DANGEROUS**” placard, and is marked as

well for explosives, extremely toxic, and high strength radioactive materials when they are present. Other than for radioactive materials, a multiple-hazard material is marked only with the name of the most severe hazard present. A rail car carrying hazardous materials of various hazard classes must be marked with all applicable placards.

METHOD OF SURVEY

The hazardous material (Haz/Mat) railroad survey was conducted for three separate 24-hour periods. The time periods included: 0600 on Thursday, October 9 to 0600 on Friday, October 10 in 1997; midnight to midnight on Thursday, April 16, 1998; and midnight to midnight on Friday, July 24, 1998. The three survey periods allow comparisons between various seasons. A winter survey during January 1998 was originally planned, but was not conducted due to scheduling problems.

CSXT and CONRAIL each have one main line running through the two-county emergency planning district. During the study period, the proposed breakup of CONRAIL and subsequent acquisition by both CSXT and Norfolk Southern was being considered. The proposal had not been approved at the time the study was completed. Due to limited funding and availability of personnel, the survey was restricted to a downtown site where the two main line rail tracks run adjacent to each other. The location of the survey point in relation to the existing railroad lines in the area is shown on Map 1.

Two members of the survey team were stationed at the survey site at all times and recorded the following information:

- Time the train passed the survey site
- What track the train used
- Direction of travel by the train
- Number and type of train cars
- Number ID and car type for placarded cars

Placards were recorded according to the number or word seen on the placard. Due to limited funding, this study did not attempt to determine the accuracy of the placarding of the train cars observed. A videotape of most trains was made in order to verify the information recorded.

Appendix A contains a complete listing of the types and numbers of placards observed by train. Appendix B is a key which identifies the substances associated with the observed placards. Information on additional placard numbers or types can be obtained from the U.S. Department of Transportation Emergency Response Guidebook.

Map 1
LOCATION OF HAZ/MAT
RAILROAD SURVEY POINT

Greene & Montgomery
Counties

--- Road
— Railway

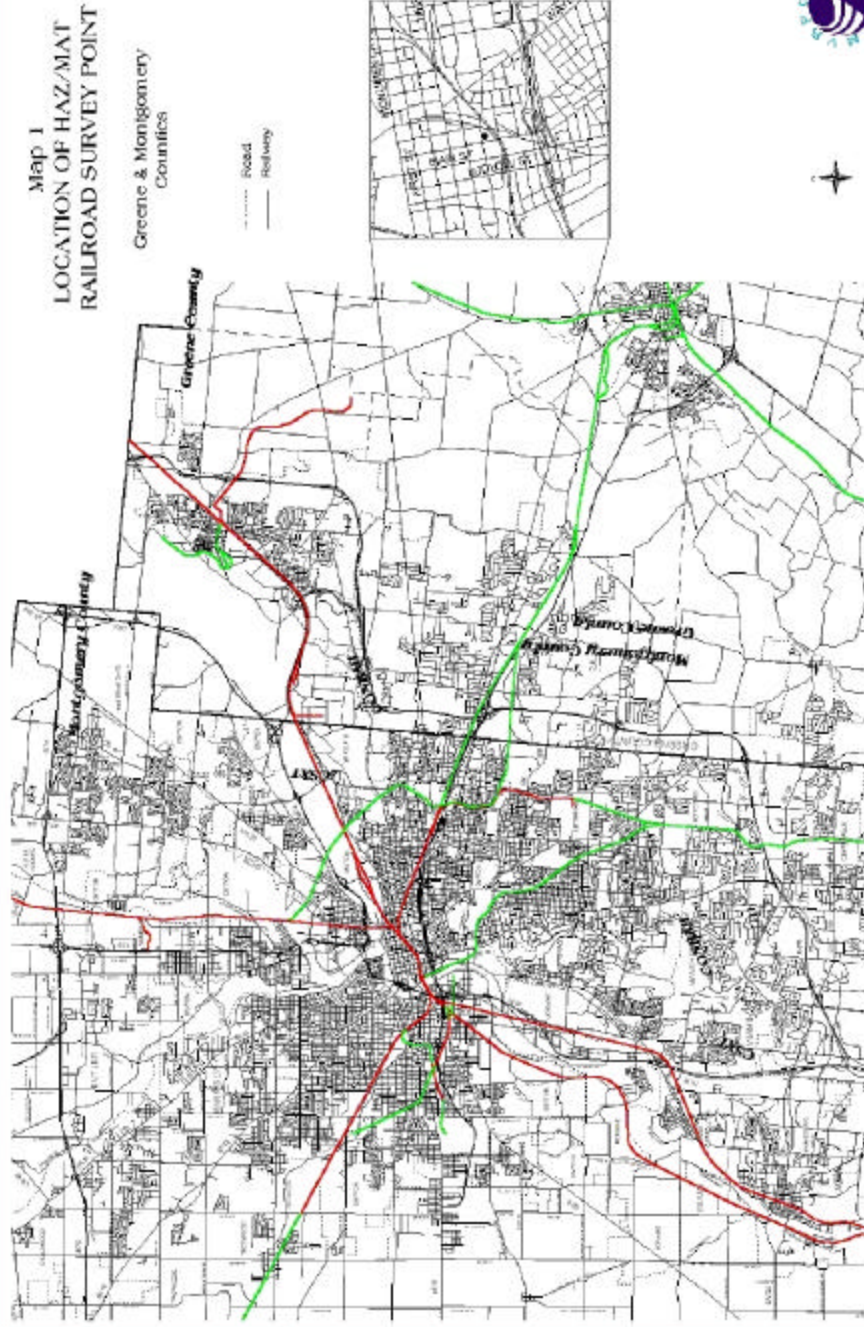

RESULTS BY RAILROAD CAR TYPE

Almost all of the 466 placards observed were on tank cars. Only three were on other types of cars. A total of 843 tank cars were seen and 463 were placarded, resulting in about 55% of the tank cars having placards. Only 1 of the 1,213 covered hoppers were placarded. Two of the 117 containers on flatcar (COFC) were placarded. No rail cars with multiple placards were seen. The 466 placarded cars represent 6.3% of all train cars observed. Higher percentages of railroad cars were placarded during the night, with 8.4% of all train cars placarded during the 2100-0300 time period.

RESULTS BY SURVEY DATE

A summary of the railroad Haz/Mat survey results is provided in Table 1. A total of 54, 50, and 37 trains were observed in October, April, and July, respectively. The lower number of trains in July was probably influenced by a workers strike affecting many General Motors plants, including those in the Dayton area. A comparison of car types showed a marked decrease in auto carriers during the July survey. However, the number of trains carrying hazardous materials and the number of placards observed did not seem to be affected. In fact, the number of placards observed in July was almost twice the number observed in October, and one-third higher than the number observed in April.

Over the three dates, a total of 70 different types of placards were observed at the survey location. There was no significant fluctuation in the number of different placard types observed among the three survey dates. Placard #1075 (Propane, LPG gas) was the most frequently observed placard overall and on each of the three survey dates. Also, a higher percentage of train cars were placarded during the July survey than on the other two survey dates. This was possibly due to the reduced number of auto carriers seen during the July survey.

RESULTS BY TIME-OF-DAY

The findings of the survey related to time-of-day are summarized in Table 2. Times periods are denoted in military time. A combined total of 141 trains were observed during the three survey periods. The 1500-1800 time period had the highest number of trains, followed by the 0300-0600 and 1800-2100 time periods, respectively.

The highest number of placards were observed during the 0300-0600 time period. The next-highest numbers were observed during the 2100-2400 and 000-0300 time periods, respectively. The 1200-1500 time period had both the fewest trains and fewest placard observations. In examining total numbers of train cars, the highest percentage of those placarded were seen between 2100-0300. The numbers and types of placards observed was much less varied between 0900-1500.

TABLE 1
SUMMARY OF RAILROAD HAZ/MAT SURVEY BY SURVEY DATE
MONTGOMERY & GREENE COUNTIES
1997-1998

SURVEY DATE	TRAINS OBSERVED	HAZ/MAT TRAINS OBSERVED	HAZ/MAT TRAINS AS PERCENT OF ALL TRAINS	TRAIN CARS OBSERVED	HAZ/MAT TRAIN CARS OBSERVED	HAZ/MAT CARS AS PERCENT OF ALL TRAIN CARS	MOST FREQUENTLY OBSERVED PLACARD ID	TOTAL NUMBER OF OBSERVATIONS OF MOST FREQUENTLY OBSERVED PLACARD	TOTAL NUMBER OF PLACARDS OBSERVED	TOTAL NUMBER OF PLACARD TYPES OBSERVED
OCTOBER 1997	54	23	42.6%	2,511	109	4.3%	#1075	16	109	39
APRIL 1998	50	24	48.0%	2,632	154	5.9%	# 1075	30	154	38
JULY 1998	37	24	64.9%	2,211	203	9.2%	# 1075	50	203	41
COMBINED TOTAL	141	71	50.4%	7,354	466	6.3%	# 1075	96	466	70

See Appendix B for Placard ID explanation.

SOURCE: Railroad survey conducted by MVRPC and MVEMA for Montgomery/Greene County Local Emergency Response Council. Surveys conducted for 24-hour periods on 10/9-10/97, 4/16/98, and 7/24/98.

**TABLE 2
SUMMARY OF RAILROAD HAZ/MAT SURVEY BY TIME-OF-DAY
MONTGOMERY & GREENE COUNTIES
1997-1998**

TIME PERIODS*	TRAINS OBSERVED	HAZ/MAT TRAINS OBSERVED	HAZ/MAT TRAINS AS PERCENT OF ALL TRAINS	TRAIN CARS OBSERVED	HAZ/MAT TRAIN CARS OBSERVED	HAZ/MAT CARS AS PERCENT OF ALL TRAIN CARS	MOST FREQUENTLY OBSERVED PLACARD ID	TOTAL NUMBER OF OBSERVATIONS OF MOST FREQUENTLY OBSERVED PLACARD	TOTAL NUMBER OF PLACARDS OBSERVED	TOTAL NUMBER OF PLACARD TYPES OBSERVED
0-300	16	8	50.0%	937	79	8.4%	# 1830	15	79	20
300-600	22	14	63.6%	1,329	91	6.8%	# 1075	27	91	26
600-900	18	12	66.7%	929	72	7.8%	# 1993	21	72	22
900-1200	13	7	53.8%	621	23	3.7%	# 1017	6	23	11
1200-1500	10	6	60.0%	499	25	5.0%	# 1075	6	25	9
1500-1800	24	10	41.7%	1,175	53	4.5%	# 1075	8	53	20
1800-2100	20	7	35.0%	909	43	4.7%	# 1075	18	43	17
2100-2400	18	7	38.9%	955	80	8.4%	# 1075	31	80	21
COMBINED TOTAL	141	71	50.4%	7,354	466	6.3%	# 1075	96	466	70

* Time shown in military format
See Appendix B for Placard ID explanation.

SOURCE: Railroad survey conducted by MVRPC and MVEMA for Montgomery/Greene County Local Emergency Response Council.
Surveys conducted for 24-hour periods on 10/9-10/97, 4/16/98, and 7/24/98.

Placard #1075 (Propane, LPG gas) was the most frequently observed placard during five of the eight time periods. The most frequently observed placards during the other time periods were Placard #1830 during the 000-0300 period, Placard #1993 during the 0600-0900 period, and Placard #1017 during the 0900-1200 period. Most of the frequently seen placard IDs within a time period were due to a string of tank cars on one or two trains observed during that time period. For example, the 27 observations of Placard #1075 during the 0300-0600 time period were seen on two trains, one with 15 and the other with 12. The one exception was the six observations of Placard #1017, seen on four different trains during the 1200-1500 time period.

RESULTS BY TYPE OF PLACARD

As shown in Table 3, 70 different types of placards were observed during the three survey periods. Only 23 placard types were observed just once, representing about 5% of the total placard observations. About 32% of the placard types were observed 2-9 times. Ten placard types were observed more than 10 times accounting for approximately 63% of all placard observations. Except for one placard marked “EXPLOSIVES” placed on a container on a flatcar, no generic hazard class placards such as “DANGEROUS,” “FLAMMABLE,” or “CORROSIVE” were seen on the rail cars. In comparison, these generic-type hazard class placards were observed frequently during the hazardous materials truck survey conducted in 1994.

**TABLE 3
OBSERVATION FREQUENCY OF PLACARD TYPES
1997-1998 RAILROAD HAZ/MAT SURVEY**

OBSERVATION FREQUENCY	NUMBER OF PLACARD TYPES	PERCENT
1	23	32.8%
2-5	28	40.0%
6-9	9	12.9%
10+	10	14.3%
TOTAL NUMBER OF TYPES	70	100.0%

Source: Survey conducted by MVRPC and MVEMA for MGCLERC.
Surveys conducted for 24-hour periods on 10/9-10/97, 4/16/98, and 7/24/98.

RESULTS BY RAILROAD

The findings of the survey related to railroad are summarized in Table 4. A total of 60 trains on CONRAIL tracks and 81 on CSXT tracks were observed over the three survey periods. Placarded cars were observed on just under one-half of trains on the CONRAIL tracks and just over one-half of trains on the CSXT tracks. Trains on the CSXT tracks carried a total of 316 placarded cars, a little more than twice the 150 placarded cars observed on the CONRAIL tracks. Trains on the CSXT tracks also had a larger number of placard types.

TABLE 4
SUMMARY OF RAILROAD HAZMAT SURVEY BY RAILROAD
MONTGOMERY & GREENE COUNTIES
1997-1998

SURVEY DATE	TRAINS OBSERVED	HAZ/MAT TRAINS OBSERVED	HAZ/MAT TRAINS AS PERCENT OF ALL TRAINS	TRAIN CARS OBSERVED	HAZ/MAT TRAIN CARS OBSERVED	HAZMAT CARS AS PERCENT OF ALL TRAIN CARS	MOST FREQUENTLY OBSERVED PLACARD ID	TOTAL NUMBER OF OBSERVATIONS OF MOST FREQUENTLY OBSERVED PLACARD	TOTAL NUMBER OF PLACARDS OBSERVED	TOTAL NUMBER OF PLACARD TYPES OBSERVED
CONRAIL NORTHBOUND	29	12	41.4%	1,634	73	4.5%	# 1993	17	73	20
CONRAIL SOUTHBOUND	31	17	54.8%	1,638	77	4.7%	# 3082	16	77	22
CONRAIL TOTAL	60	29	48.3%	3,272	150	4.6%	# 1993	25	150	33
CSXT NORTHBOUND	37	22	59.5%	2,068	167	8.1%	# 1075	45	167	44
CSXT SOUTHBOUND	44	20	45.5%	2,014	149	7.4%	# 1075	47	149	33
CSXT TOTAL	81	42	51.9%	4,082	316	7.7%	# 1075	92	316	56

See Appendix B for Placard ID explanation.

SOURCE: Railroad survey conducted by MVRPC and MVEMA for Montgomery/Greene County Local Emergency Response Council. Surveys conducted for 24-hour periods on 10/9-10/97, 4/16/98, and 7/24/98.

Examining the total number of train cars, 7.7% of rail cars on the CSXT tracks were placarded while 4.6% of all cars on the CONRAIL tracks were placarded. Regarding direction of travel, a slightly higher percentage of northbound cars on the CSXT tracks were placarded, while placarded cars on the CONRAIL tracks were essentially split evenly.

The most frequently observed placard on CSXT trains was #**1075**, both overall and in both directions of travel. Placard #**1993** was the most frequently observed on CONRAIL trains, including northbound trains. Placard #**3082** was the most frequently observed on southbound CONRAIL trains. Of all 70 placard types observed, 37 were seen only on CSXT trains, 14 were seen only on CONRAIL trains, and 19 were seen on both railroads.

MOST FREQUENTLY OBSERVED PLACARD TYPES

Table 5 shows the ten most frequently observed placard types during the course of the study. These hazardous materials constituted about 63% of all placard observations. This section discusses these hazardous materials.

Placard #**1075** (Butane, Isobutane, Liquefied Petroleum, or Propane) was the most frequently observed placard. The 96 observations of placard #1075 were approximately 21% of all observations. Most of the shipments were observed at night between 1800-0600. Almost all of the shipments were observed using the CSXT tracks, were about equally split northbound- southbound, and one-half were observed in July.

Placard #**3082** (Environmentally Hazardous Substances, n.o.s.) was the second most frequently observed placard. The 42 observations of placard #3082 were approximately 9% of all observations. Most of the shipments were observed between 1800-0600. The observations of this placard were equally split between the CONRAIL tracks and the CSXT tracks, most were observed going southbound, and approximately one-half were observed in July.

Placard #**1993** (Flammable Liquid, poisonous; Combustible Liquid; Compounds, cleaning, liquid; Fuel Oil) was the third most frequently seen placard, having been observed 32 times. Most of the placards were observed between 0600-0900, due in part to one train with 15 such placards. The observations of this placard were primarily made on the CONRAIL tracks, most were observed going northbound, and about two-thirds were observed in July.

Placard #**1830** (Sulfuric Acid) was the fourth most frequently seen placard, having 30 observations. One-half of the placards were observed during the 000-0300 time period, due in part to two trains with 15 such placards. The observations of this placard were primarily made on the CSXT tracks, most were observed going northbound, and approximately 70% were observed in April.

Placard #**3257** (Elevated Temperature Liquid, n.o.s., at or above 100°C and below its flash point) was

the fifth most frequently observed placard, having 29 observations. Most of these placards were observed during the 000-0600 time period, due in part to two trains with 17 such placards. The observations of this placard were primarily made on the CSXT tracks. Northbound and southbound shipments were about evenly split, as well as observations over the three survey periods.

Placard #1017 (Chlorine) was the sixth most frequently seen placard, having been observed 21 times. Most of the placards were observed between 0600-1800. Most trains only had one or two cars with these placards, but one had 5 cars. CONRAIL had only three more of these placards than CSXT. Most CONRAIL shipments were observed going southbound and most CSXT shipments were observed going northbound. Most of these placards were seen in April and July.

Placard #1010 (Butadienes, inhibited) was tied as the seventh most frequently seen placard, having been observed 12 times. Most of these placards were observed during the 000-0300 time period. These placards were only seen on the CSXT tracks. The shipments were about evenly distributed going southbound and northbound and were also evenly distributed over the three survey periods.

Placard #2448 (Molten Sulfur) was tied as the seventh most frequently observed placard, having been seen 12 times. One-half of these placards were observed between 0600-1500. Most observations were single shipments. The observations of this placard were almost all made on the CSXT tracks, most were going southbound, and most were in April and July.

Placard #1041 (Carbon Dioxide & Ethylene Oxide Mixture) was tied for the ninth most frequently seen placard, having been observed 11 times. All 11 of these placards were observed during the 000-0300 time period on one train traveling southbound on the CONRAIL tracks in July.

Placard #1824 (Caustic Soda, solution; Sodium Hydroxide, solution) was tied for the ninth most frequently seen placard, being observed 11 times. The observations were split about evenly between the 000-0600 and the 0900-1500 time periods. Most observations were single shipments on the CONRAIL tracks going northbound, and observed in October.

EXTREMELY HAZARDOUS SUBSTANCES (EHS) PLACARDS

Table 6 shows the observed placard types for extremely hazardous substances (EHS) during the course of the study. These extremely hazardous substances accounted for 104 of the 466 placard observations, approximately 22% of the total. Placards for EHS were observed most frequently in the 000-0300 and the 1500-1800 time periods. About 60% of the EHS placards were observed on the CSXT tracks. Most EHS on the CSXT tracks were traveling northbound, while most on the CONRAIL tracks were traveling southbound. A much greater number of EHS placards were observed during the April and July survey dates than the October date.

**TABLE 5
TEN MOST FREQUENTLY OBSERVED PLACARD IDs
RAILROAD HAZ/MAT SURVEY
1997-1998**

PLACARD ID*	1075	3082	1993	1830	3257	1017	1010	2448	1041	1824
TOTAL OBSERVATIONS	96	43	32	30	29	21	12	12	11	11

TIME PERIODS OBSERVED

0-300	1	12	0	15	10	5	7	0	11	3
300-600	27	12	1	1	8	0	0	2	0	2
600-900	4	6	21	5	1	4	2	4	0	0
900-1200	1	0	1	0	2	6	0	0	0	5
1200-1500	6	1	0	0	3	2	0	4	0	1
1500-1800	8	1	1	6	3	4	3	0	0	0
1800-2100	18	3	3	0	0	0	0	2	0	0
2100-2400	31	8	5	3	2	0	0	0	0	0

RAILROAD & DIRECTION

CONRAIL	4	21	25	9	5	12	0	2	11	9
NB	2	5	17	9	3	4	0	0	0	6
SB	2	16	8	0	2	8	0	2	11	3
CSXT	92	21	7	21	24	9	12	10	0	2
NB	45	4	6	11	11	7	7	2	0	1
SB	47	17	1	10	13	2	5	8	0	1

SURVEY MONTH

OCT	16	11	3	3	9	2	4	2	0	7
APR	30	10	7	21	9	9	4	5	0	3
JUL	50	21	22	6	11	10	4	5	11	1

* NOTE: See Appendix B for Placard ID explanation.

SOURCE: Railroad survey conducted by MVRPC and MVEMA for Montgomery/Greene County Local Emergency Response Council. Surveys conducted for 24-hour periods on 10/9-10/97, 4/16/98, and 7/24/98.

**TABLE 6
EXTREMELY HAZARDOUS SUBSTANCES OBSERVED
RAILROAD HAZ/MAT SURVEY
1997-1998**

PLACARD ID*	1005	1017	1041	1050	1079	1093	1131	1298	1760	1789	1830	2014	2015	2074	ALL EHS
OBSERVATIONS	2	21	11	1	4	7	1	4	4	9	30	1	3	6	104

TIME PERIOD (Military Time)

0-300	0	5	11	0	0	0	1	0	0	1	15	1	0	0	34
300-600	0	0	0	1	0	1	0	0	3	0	1	0	0	1	7
600-900	0	4	0	0	0	0	0	0	1	0	5	0	0	0	10
900-1200	0	6	0	0	0	0	0	0	0	2	0	0	1	0	9
1200-1500	0	2	0	0	0	0	0	0	0	1	0	0	2	0	5
1500-1800	2	4	0	0	3	6	0	0	0	2	6	0	0	0	23
1800-2100	0	0	0	0	1	0	0	0	0	1	0	0	0	3	5
2100-2400	0	0	0	0	0	0	0	4	0	2	3	0	0	2	11

RAILROAD & DIRECTION

CONRAIL	0	12	11	0	1	0	1	0	3	5	9	0	2	0	44
NB	0	4	0	0	0	0	1	0	1	4	9	0	0	0	19
SB	0	8	11	0	1	0	0	0	2	1	0	0	2	0	25
CSXT	2	9	0	1	3	7	0	4	1	4	21	1	1	6	60
NB	2	7	0	1	3	7	0	3	1	2	11	0	1	0	38
SB	0	2	0	0	0	0	0	1	0	2	10	1	0	6	22

SURVEY MONTH

OCT	0	2	0	0	1	0	0	3	3	1	3	1	0	2	16
APR	1	9	0	0	1	4	1	1	0	6	21	0	2	2	48
JUL	1	10	11	1	2	3	0	0	1	2	6	0	1	2	40

* NOTE: See Appendix B for Placard ID explanation.

SOURCE: Railroad survey conducted by MVRPC and MVEMA for Montgomery/Greene County Local Emergency Response Council. Surveys conducted for 24-hour periods on 10/16-17/97, 4/16/98, and 7/24/98.

The following is a more detailed discussion on each individual EHS placard observed:

Placard #**1005** (Anhydrous Ammonia) was observed two times, once in April and once in July. Each observation was during the 1500-1800 time period northbound on the CSXT tracks.

Placard #**1017** (Chlorine) was observed 21 times. Most of the placards were observed between 0600-1800. Most trains only had one or two cars with these placards, although one had 5 such cars. CONRAIL had only three more of these placards than CSXT. Most CONRAIL shipments were observed going southbound and most CSXT shipments were observed going northbound. Most of these placards were seen in April and July.

Placard #**1041** (Carbon Dioxide & Ethylene Oxide Mixture) was observed 11 times. All eleven placards were observed during the 000-0300 time period on one train traveling southbound on the CONRAIL tracks in July.

Placard #**1050** (Hydrogen Chloride, anhydrous) was observed once. It was seen during the 0300-0600 time period on traveling northbound on the CSXT tracks in July.

Placard #**1079** (Sulfur Dioxide) was observed four times. All of these placards were observed in the 1500-2100 time period. Three of the four observations were southbound on the CSXT tracks. These placards were seen on all three survey dates.

Placard #**1093** (Acrylonitrile, inhibited) was observed seven times, all northbound on the CSXT tracks. Six of the seven observations were in the 1500-1800 time period. Three of the four observations were southbound on the CSXT tracks. These placards were seen in April and July.

Placard #**1131** (Carbon Disulfide) was observed once. It was seen during the 000-0300 time period traveling northbound on the CONRAIL tracks in July.

Placard #**1298** (Trimethylchlorosilane) was observed four times. All of these placards were observed in the 2100-2400 time period. Three of the four observations were northbound on the CSXT tracks. These placards were seen in October and April.

Placard #**1760** (Nitric Acid - See Appendix B) was observed four times. All of these placards were observed in the 0300-0900 time period. Three of the four observations were on the CONRAIL tracks. Three of the four placards were seen in October.

Placard #**1789** (Hydrochloric Acid) was observed nine times. These placards were observed in all time periods except 0300-0900. Most trains only had one or two cars with these placards. These observations were almost evenly split between the CONRAIL and the CSXT tracks. Most CONRAIL shipments were observed going northbound while the CSXT shipments were evenly split. Most of these placards were seen in April.

Placard #1830 (Sulfuric Acid) was observed 30 times. One-half of the placards were observed during the 000-0300 time period, due in part to two trains with 15 such placards. The observations of this placard were primarily made on the CSXT tracks. Most were observed going northbound. About 70% were observed in April.

Placard #2014 (Hydrogen Peroxide, aqueous solution, with not less than 20% but not more than 60% Hydrogen Peroxide [stabilized as necessary]) was observed once. It was seen during the 000-0300 time period traveling southbound on the CSXT tracks in October.

Placard #2015 (Hydrogen Peroxide, aqueous solution, stabilized, with more than 60% Hydrogen Peroxide) was observed three times. It was seen during the 0900-1500 time period. Two observations were made northbound on the CONRAIL tracks in April and one on the southbound CSXT tracks in July.

Placard #2074 (Acrylamide) was observed six times, all southbound on the CSXT tracks. Five of the six observations were in the 2100-2400 time period. Two of these placards were seen in each of the three survey periods.

SUMMARY

Results by Survey Date

- Over the three dates, a total of 70 different types of placards were observed at the survey location.
- There was no significant fluctuation in the number of different placard types observed among the three survey dates.
- Placard #1075 (Propane, LPG gas) was the most frequently observed placard overall and on each of the three survey dates.

Results by Time-of Day

- Most placarded rail cars travel through the area during the night.
- The highest number of placards were observed during the 0300-0600 time period. The next-highest numbers were observed during the 2100-2400 and 000-0300 time periods, respectively.

- The 1200-1500 time period had both the fewest trains and fewest placard observations.
- Regarding total numbers of train cars, the highest percentage of those placarded were seen between 2100-0300.

Results by Railroad

- Trains on CSXT tracks carried a total of 316 placarded cars, a little more than twice the 150 placarded cars carried on CONRAIL trains.
- Trains on CSXT tracks had a larger number of placard types than those on CONRAIL.
- 7.7% of rail cars on CSXT were placarded while 4.6% of all rail cars on CONRAIL were placarded.
- The most frequently observed placard on trains using CSXT tracks was **#1075**, both overall and in both directions of travel.
- Placard **#1993** was the most frequently observed overall on all trains using the CONRAIL tracks and on northbound trains using CONRAIL tracks. Placard **#3082** was the most frequently observed on southbound trains using the CONRAIL tracks.

Results by Type of Placards

- The study shows a variety of hazardous material shipments on the railroads running past the study point, but only a few types of such shipments have a very high frequency.
- 70 different types of placards were observed during the three survey periods.
- Only 23 placard types were observed just once, representing about 5% of the total placard observations.
- Ten placard types were observed more than 10 times accounting for approximately 63% of all placard observations.
- Placard **#1075** (Butane, Isobutane, Liquefied Petroleum, or Propane) was the most frequently observed placard, being observed 96 times. Most of the shipments were at night between 1800-0600 and almost all were on the CSXT tracks
- The next most frequently seen placards were:
 - #3082** (Environmentally Hazardous Substances, n.o.s.)

#1993 (Flammable Liquid, poisonous; Combustible Liquid; Fuel Oil; etc.)
#1830 (Sulfuric Acid)
#3257 (Elevated Temperature Liquid, n.o.s., at or above 100°C and below its flash point)
#1017 (Chlorine)

- No rail cars with multiple placards were seen.
- Except for one placard marked “EXPLOSIVES” upon a container on a flatcar, no generic placards such as “DANGEROUS” or “CORROSIVE” were seen on the rail cars.

Extremely Hazardous Substances

- 14 different types of placards denoting extremely hazardous substances were observed.
- Extremely hazardous substances accounted for 104 of the 466 placard observations, approximately 22% of the total.
- Placards for EHS were observed most frequently in the 000-0300 and the 1500-1800 time periods.
- About 60% of the EHS placards were observed on the CSXT tracks.
- Most EHS on the CSXT tracks were traveling northbound, while most on the CONRAIL tracks were traveling southbound.
- A much greater number of EHS placards were observed during the April and July survey dates than the October date.
- Placard #1830 (Sulfuric Acid) was the EHS placard observed the most. It was seen a total of 30 times and primarily on the CSXT tracks.
- Placard #1017 (Chlorine) was the second most observed EHS placard. It was seen 21 times.

Results by Type of Rail Car

- All but 3 of the 466 observed placards were on tank cars and about 55% of all tank cars were placarded.
- The three placards not on tank cars were on 1 covered hopper and 2 containers on flat cars (COFC).

This study is part of MGCLERC's program to monitor hazardous materials shipments in the Greene and Montgomery County area. Future studies should attempt to expand the survey to include locations both north and south of the downtown site to find out what materials are brought into the area and dropped off at both the CSXT rail yard north of town and the CONRAIL yard in Moraine. The results of this study will be distributed to local emergency response entities and will be used by the MGCLERC to conduct hazard analysis and risk assessment along the existing railroad corridors. The primary focus of local hazardous materials response planning should be on the types of shipments with higher frequencies. Area fire, law enforcement, and medical responders should, however, be made aware of all of the various types of hazardous materials shipments on our railroads.

Appendix A

Placard Observations by Train

Full Data Table

October, 1997

April, 1998

July, 1998

HAZARDOUS MATERIALS RAILROAD SURVEY

GREENE & MONTOMERY COUNTIES, OHIO

**APPENDIX A
FULL DATA TABLE
RAILROAD HAZ/MAT SURVEY**

DATE	TIME (Military)	TRACK	DIR	TOTAL PLACARDS	NUMBER OF PLACARD ID OBSERVATIONS (See Appendix B)														
					1005	1010	1014	1017	1038	1041	1050	1055	1063	1075	1079	1090	1093	1114	
10/09/1997	0615	CON	S	1											1				
10/09/1997	0655	CSX	S	5													1		
10/09/1997	0750	CON	S	1				1											
10/09/1997	0840	CSX	N	6										2					
10/09/1997	0952	CON	S	4				1											
10/09/1997	1010	CON	N	4															
10/09/1997	1500	CON	N	2															
10/09/1997	1740	CSX	N	6		3													
10/09/1997	1845	CON	S	1												1			
10/09/1997	1848	CSX	N	6										1					
10/09/1997	1955	CON	S	3															
10/09/1997	2015	CSX	N	2															
10/09/1997	2140	CSX	S	13										9					
10/09/1997	2155	CSX	S	2															
10/09/1997	2335	CSX	N	17									4	3					
10/10/1997	0027	CON	S	2															
10/10/1997	0200	CSX	S	4		1						1							
10/10/1997	0310	CSX	S	8															
10/10/1997	0350	CON	S	2															
10/10/1997	0405	CON	S	2															
10/10/1997	0447	CSX	S	9															
10/10/1997	0451	CON	N	3															
10/10/1997	0524	CON	N	6															1
04/16/1998	0037	CON	N	12			1												
04/16/1998	0045	CSX	S	11															
04/16/1998	0101	CSX	S	7		4													
04/16/1998	0345	CON	S	3			3												
04/16/1998	0410	CON	N	1															
04/16/1998	0654	CSX	N	1															
04/16/1998	0758	CSX	N	9															
04/16/1998	0820	CSX	N	5															
04/16/1998	0939	CSX	N	3										1					
04/16/1998	1010	CSX	N	3				2											
04/16/1998	1032	CSX	N	3				2											
04/16/1998	1043	CON	N	5				1											
04/16/1998	1142	CON	S	1															
04/16/1998	1209	CSX	S	4				1											
04/16/1998	1303	CSX	S	8				1						1					
04/16/1998	1456	CSX	N	1															
04/16/1998	1527	CON	N	4				1											
04/16/1998	1527	CSX	N	12	1										1			4	

SOURCE: Survey conducted by MVRPC and MVEMA for Montgomery/Greene County Local Emergency Response Council.
Surveys conducted for 24-hour periods on 10/9-10/97, 4/16/98, and 7/24/98.

**APPENDIX A
FULL DATA TABLE
RAILROAD HAZ/MAT SURVEY**

DATE	TIME (Military)	TRACK	DIR	TOTAL PLACARDS	NUMBER OF PLACARD ID OBSERVATIONS (See Appendix B)													
					1005	1010	1014	1017	1038	1041	1050	1055	1063	1075	1079	1090	1093	1114
04/16/1998	1715	CSX	S	1			1											
04/16/1998	1716	CON	S	1				1										
04/16/1998	1833	CSX	S	16								1	9					
04/16/1998	2240	CSX	S	9														
04/16/1998	2256	CON	S	8														
04/16/1998	2306	CSX	N	26									19					
07/24/1998	0015	CSX	N	2		2												
07/24/1998	0104	CON	S	28				5	2	11								
07/24/1998	0155	CSX	N	13									1					
07/24/1998	0305	CSX	S	3														
07/24/1998	0312	CSX	N	2													1	
07/24/1998	0355	CSX	S	7												1		
07/24/1998	0445	CON	N	7														
07/24/1998	0508	CSX	S	19									15					
07/24/1998	0535	CSX	N	19						1			12					
07/24/1998	0610	CSX	N	2														
07/24/1998	0635	CSX	N	6									1					
07/24/1998	0819	CSX	S	4														
07/24/1998	0823	CON	N	22														
07/24/1998	0841	CSX	N	10		2		3				1						
07/24/1998	1237	CSX	S	5									5					
07/24/1998	1326	CON	S	5														
07/24/1998	1350	CON	S	2														
07/24/1998	1640	CON	S	7									1					
07/24/1998	1700	CON	N	3				1										
07/24/1998	1715	CON	N	4				1					2					
07/24/1998	1755	CSX	N	13	1								5	2			2	
07/24/1998	1950	CSX	S	9									8					
07/24/1998	2009	CON	S	6														
07/24/1998	2101	CSX	S	5														

TOTAL FOR OCTOBER 1997	109	0	4	0	2	0	0	0	1	4	16	1	1	0	1
TOTAL FOR APRIL 1998	154	1	4	5	9	0	0	0	0	1	30	1	0	4	0
TOTAL FOR JULY 1998	203	1	4	0	10	2	11	1	1	0	50	2	1	3	0
TOTALS	466	2	12	5	21	2	11	1	2	5	96	4	2	7	1

**APPENDIX A
FULL DATA TABLE
RAILROAD HAZ/MAT SURVEY**

DATE	TIME (Military)	TRACK	DIR	TOTAL PLACARDS	NUMBER OF PLACARD ID OBSERVATIONS (See Appendix B)												
					1131	1193	1203	1210	1218	1219	1235	1242	1250	1256	1268	1276	1294
10/09/1997	0615	CON	S	1													
10/09/1997	0655	CSX	S	5													
10/09/1997	0750	CON	S	1													
10/09/1997	0840	CSX	N	6										1			
10/09/1997	0952	CON	S	4													
10/09/1997	1010	CON	N	4													
10/09/1997	1500	CON	N	2													
10/09/1997	1740	CSX	N	6													
10/09/1997	1845	CON	S	1													
10/09/1997	1848	CSX	N	6												1	
10/09/1997	1955	CON	S	3													
10/09/1997	2015	CSX	N	2													
10/09/1997	2140	CSX	S	13								1					1
10/09/1997	2155	CSX	S	2													
10/09/1997	2335	CSX	N	17							2		2				2
10/10/1997	0027	CON	S	2													
10/10/1997	0200	CSX	S	4													
10/10/1997	0310	CSX	S	8													
10/10/1997	0350	CON	S	2													
10/10/1997	0405	CON	S	2													
10/10/1997	0447	CSX	S	9													
10/10/1997	0451	CON	N	3													
10/10/1997	0524	CON	N	6											2		
04/16/1998	0037	CON	N	12	1												
04/16/1998	0045	CSX	S	11					1								
04/16/1998	0101	CSX	S	7													
04/16/1998	0345	CON	S	3													
04/16/1998	0410	CON	N	1													
04/16/1998	0654	CSX	N	1						1							
04/16/1998	0758	CSX	N	9		1								1			
04/16/1998	0820	CSX	N	5										1			
04/16/1998	0939	CSX	N	3			2										
04/16/1998	1010	CSX	N	3													
04/16/1998	1032	CSX	N	3													
04/16/1998	1043	CON	N	5													
04/16/1998	1142	CON	S	1													
04/16/1998	1209	CSX	S	4													
04/16/1998	1303	CSX	S	8													
04/16/1998	1456	CSX	N	1													
04/16/1998	1527	CON	N	4													
04/16/1998	1527	CSX	N	12													

SOURCE: Survey conducted by MVRPC and MVEMA for Montgomery/Greene County Local Emergency Response Council.
Surveys conducted for 24-hour periods on 10/9-10/97, 4/16/98, and 7/24/98.

**APPENDIX A
FULL DATA TABLE
RAILROAD HAZ/MAT SURVEY**

DATE	TIME (Military)	TRACK	DIR	TOTAL PLACARDS	NUMBER OF PLACARD ID OBSERVATIONS (See Appendix B)													
					1131	1193	1203	1210	1218	1219	1235	1242	1250	1256	1268	1276	1294	1298
04/16/1998	1715	CSX	S	1														
04/16/1998	1716	CON	S	1														
04/16/1998	1833	CSX	S	16			1					1						
04/16/1998	2240	CSX	S	9														
04/16/1998	2256	CON	S	8														
04/16/1998	2306	CSX	N	26						1							1	1
07/24/1998	0015	CSX	N	2														
07/24/1998	0104	CON	S	28														
07/24/1998	0155	CSX	N	13					1									
07/24/1998	0305	CSX	S	3													1	
07/24/1998	0312	CSX	N	2														
07/24/1998	0355	CSX	S	7														
07/24/1998	0445	CON	N	7														
07/24/1998	0508	CSX	S	19			1											
07/24/1998	0535	CSX	N	19														
07/24/1998	0610	CSX	N	2										1				
07/24/1998	0635	CSX	N	6														
07/24/1998	0819	CSX	S	4														
07/24/1998	0823	CON	N	22														
07/24/1998	0841	CSX	N	10														
07/24/1998	1237	CSX	S	5														
07/24/1998	1326	CON	S	5										5				
07/24/1998	1350	CON	S	2														
07/24/1998	1640	CON	S	7				1									1	
07/24/1998	1700	CON	N	3														
07/24/1998	1715	CON	N	4														
07/24/1998	1755	CSX	N	13													2	
07/24/1998	1950	CSX	S	9														
07/24/1998	2009	CON	S	6														
07/24/1998	2101	CSX	S	5														

TOTAL FOR OCTOBER 1997	109	0	0	0	0	0	0	0	0	2	1	2	1	2	1	3
TOTAL FOR APRIL 1998	154	1	1	3	0	0	2	1	1	0	0	2	0	1	1	
TOTAL FOR JULY 1998	203	0	0	1	1	1	0	0	0	0	0	6	0	4	0	
TOTALS	466	1	1	4	1	1	2	1	3	1	2	9	2	6	4	

**APPENDIX A
FULL DATA TABLE
RAILROAD HAZ/MAT SURVEY**

DATE	TIME (Military)	TRACK	DIR	TOTAL PLACARDS	NUMBER OF PLACARD ID OBSERVATIONS (See Appendix B)														
					1307	1382	1495	1719	1760	1778	1782	1789	1814	1824	1830	1942	1951	1987	
10/09/1997	0615	CON	S	1															
10/09/1997	0655	CSX	S	5															
10/09/1997	0750	CON	S	1															
10/09/1997	0840	CSX	N	6													1		
10/09/1997	0952	CON	S	4									1						
10/09/1997	1010	CON	N	4									3						
10/09/1997	1500	CON	N	2										1					
10/09/1997	1740	CSX	N	6															
10/09/1997	1845	CON	S	1															
10/09/1997	1848	CSX	N	6	2													1	
10/09/1997	1955	CON	S	3								1							
10/09/1997	2015	CSX	N	2															
10/09/1997	2140	CSX	S	13															
10/09/1997	2155	CSX	S	2										2					
10/09/1997	2335	CSX	N	17															
10/10/1997	0027	CON	S	2									2						
10/10/1997	0200	CSX	S	4															
10/10/1997	0310	CSX	S	8															
10/10/1997	0350	CON	S	2					2										
10/10/1997	0405	CON	S	2															
10/10/1997	0447	CSX	S	9			1												
10/10/1997	0451	CON	N	3					1					1					
10/10/1997	0524	CON	N	6															
04/16/1998	0037	CON	N	12				1					1		8				
04/16/1998	0045	CSX	S	11								1			7				
04/16/1998	0101	CSX	S	7															
04/16/1998	0345	CON	S	3															
04/16/1998	0410	CON	N	1									1						
04/16/1998	0654	CSX	N	1															
04/16/1998	0758	CSX	N	9															
04/16/1998	0820	CSX	N	5											1				
04/16/1998	0939	CSX	N	3															
04/16/1998	1010	CSX	N	3															
04/16/1998	1032	CSX	N	3															
04/16/1998	1043	CON	N	5								2	1	1					
04/16/1998	1142	CON	S	1															
04/16/1998	1209	CSX	S	4															
04/16/1998	1303	CSX	S	8								1		1					
04/16/1998	1456	CSX	N	1															
04/16/1998	1527	CON	N	4															
04/16/1998	1527	CSX	N	12										5			1		

SOURCE: Survey conducted by MVRPC and MVEMA for Montgomery/Greene County Local Emergency Response Council.
Surveys conducted for 24-hour periods on 10/9-10/97, 4/16/98, and 7/24/98.

**APPENDIX A
FULL DATA TABLE
RAILROAD HAZ/MAT SURVEY**

DATE	TIME (Military)	TRACK	DIR	TOTAL PLACARDS	NUMBER OF PLACARD ID OBSERVATIONS (See Appendix B)												
					1307	1382	1495	1719	1760	1778	1782	1789	1814	1824	1830	1942	1951
04/16/1998	1715	CSX	S	1													
04/16/1998	1716	CON	S	1													
04/16/1998	1833	CSX	S	16													
04/16/1998	2240	CSX	S	9													
04/16/1998	2256	CON	S	8													
04/16/1998	2306	CSX	N	26	1						2						
07/24/1998	0015	CSX	N	2													
07/24/1998	0104	CON	S	28													
07/24/1998	0155	CSX	N	13								1					
07/24/1998	0305	CSX	S	3		1											
07/24/1998	0312	CSX	N	2									1				
07/24/1998	0355	CSX	S	7					1								
07/24/1998	0445	CON	N	7						7							
07/24/1998	0508	CSX	S	19													
07/24/1998	0535	CSX	N	19													
07/24/1998	0610	CSX	N	2													
07/24/1998	0635	CSX	N	6									4				
07/24/1998	0819	CSX	S	4													1
07/24/1998	0823	CON	N	22													
07/24/1998	0841	CSX	N	10					1								
07/24/1998	1237	CSX	S	5													
07/24/1998	1326	CON	S	5													
07/24/1998	1350	CON	S	2													
07/24/1998	1640	CON	S	7													
07/24/1998	1700	CON	N	3							2						
07/24/1998	1715	CON	N	4													
07/24/1998	1755	CSX	N	13													
07/24/1998	1950	CSX	S	9													
07/24/1998	2009	CON	S	6													
07/24/1998	2101	CSX	S	5			1						1				

TOTAL FOR OCTOBER 1997	109	2	0	1	0	3	0	0	1	0	7	3	1	1	0
TOTAL FOR APRIL 1998	154	1	0	0	1	0	0	0	6	2	3	21	0	1	0
TOTAL FOR JULY 1998	203	0	1	1	0	1	1	7	2	0	1	6	0	0	1
TOTALS	466	3	1	2	1	4	1	7	9	2	11	30	1	2	1

**APPENDIX A
FULL DATA TABLE
RAILROAD HAZ/MAT SURVEY**

DATE	TIME (Military)	TRACK	DIR	TOTAL PLACARDS	NUMBER OF PLACARD ID OBSERVATIONS (See Appendix B)														
					1993	2014	2015	2046	2051	2055	2074	2187	2198	2348	2448	2582	2664	2810	
10/09/1997	0615	CON	S	1															
10/09/1997	0655	CSX	S	5								2							
10/09/1997	0750	CON	S	1															
10/09/1997	0840	CSX	N	6	1														
10/09/1997	0952	CON	S	4															
10/09/1997	1010	CON	N	4	1														
10/09/1997	1500	CON	N	2							1								
10/09/1997	1740	CSX	N	6					2										
10/09/1997	1845	CON	S	1															
10/09/1997	1848	CSX	N	6															
10/09/1997	1955	CON	S	3									2						
10/09/1997	2015	CSX	N	2															
10/09/1997	2140	CSX	S	13						2									
10/09/1997	2155	CSX	S	2															
10/09/1997	2335	CSX	N	17															
10/10/1997	0027	CON	S	2															
10/10/1997	0200	CSX	S	4		1							1						
10/10/1997	0310	CSX	S	8															
10/10/1997	0350	CON	S	2															
10/10/1997	0405	CON	S	2															
10/10/1997	0447	CSX	S	9	1														
10/10/1997	0451	CON	N	3				1											
10/10/1997	0524	CON	N	6															
04/16/1998	0037	CON	N	12															
04/16/1998	0045	CSX	S	11															
04/16/1998	0101	CSX	S	7								3							
04/16/1998	0345	CON	S	3															
04/16/1998	0410	CON	N	1															
04/16/1998	0654	CSX	N	1															
04/16/1998	0758	CSX	N	9	2							2							
04/16/1998	0820	CSX	N	5										1					
04/16/1998	0939	CSX	N	3															
04/16/1998	1010	CSX	N	3				1											
04/16/1998	1032	CSX	N	3															
04/16/1998	1043	CON	N	5															
04/16/1998	1142	CON	S	1			1												
04/16/1998	1209	CSX	S	4															
04/16/1998	1303	CSX	S	8									4						
04/16/1998	1456	CSX	N	1			1												
04/16/1998	1527	CON	N	4															
04/16/1998	1527	CSX	N	12															

SOURCE: Survey conducted by MVRPC and MVEMA for Montgomery/Greene County Local Emergency Response Council.
Surveys conducted for 24-hour periods on 10/9-10/97, 4/16/98, and 7/24/98.

**APPENDIX A
FULL DATA TABLE
RAILROAD HAZ/MAT SURVEY**

DATE	TIME (Military)	TRACK	DIR	TOTAL PLACARDS	NUMBER OF PLACARD ID OBSERVATIONS (See Appendix B)														
					1993	2014	2015	2046	2051	2055	2074	2187	2198	2348	2448	2582	2664	2810	
04/16/1998	1715	CSX	S	1															
04/16/1998	1716	CON	S	1															
04/16/1998	1833	CSX	S	16						2									
04/16/1998	2240	CSX	S	9															
04/16/1998	2256	CON	S	8	5													1	
04/16/1998	2306	CSX	N	26															
07/24/1998	0015	CSX	N	2															
07/24/1998	0104	CON	S	28															
07/24/1998	0155	CSX	N	13															
07/24/1998	0305	CSX	S	3												1			
07/24/1998	0312	CSX	N	2															
07/24/1998	0355	CSX	S	7															
07/24/1998	0445	CON	N	7															
07/24/1998	0508	CSX	S	19						1					1				
07/24/1998	0535	CSX	N	19								3							
07/24/1998	0610	CSX	N	2															
07/24/1998	0635	CSX	N	6											1				
07/24/1998	0819	CSX	S	4											2				
07/24/1998	0823	CON	N	22	15														
07/24/1998	0841	CSX	N	10	3														
07/24/1998	1237	CSX	S	5															
07/24/1998	1326	CON	S	5															
07/24/1998	1350	CON	S	2			1												
07/24/1998	1640	CON	S	7															
07/24/1998	1700	CON	N	3															
07/24/1998	1715	CON	N	4	1														
07/24/1998	1755	CSX	N	13															1
07/24/1998	1950	CSX	S	9						1									
07/24/1998	2009	CON	S	6	3												1		
07/24/1998	2101	CSX	S	5															2

TOTAL FOR OCTOBER 1997	109	3	1	0	0	1	2	2	3	0	1	2	0	0	0
TOTAL FOR APRIL 1998	154	7	0	2	1	0	0	2	2	0	3	5	0	1	0
TOTAL FOR JULY 1998	203	22	0	1	0	0	0	2	0	3	0	5	1	0	3
TOTALS	466	32	1	3	1	1	2	6	5	3	4	12	1	1	3

**APPENDIX A
FULL DATA TABLE
RAILROAD HAZ/MAT SURVEY**

DATE	TIME (Military)	TRACK	DIR	TOTAL PLACARDS	PLACARD ID (See Appendix B)													
					2968	2988	3002	3065	3077	3082	3219	3256	3257	3265	3272	3289	9259	EXPL
10/09/1997	0615	CON	S	1														
10/09/1997	0655	CSX	S	5										2				
10/09/1997	0750	CON	S	1														
10/09/1997	0840	CSX	N	6			1											
10/09/1997	0952	CON	S	4									2					
10/09/1997	1010	CON	N	4														
10/09/1997	1500	CON	N	2														
10/09/1997	1740	CSX	N	6					1									
10/09/1997	1845	CON	S	1														
10/09/1997	1848	CSX	N	6						1								
10/09/1997	1955	CON	S	3														
10/09/1997	2015	CSX	N	2			1		1									
10/09/1997	2140	CSX	S	13														
10/09/1997	2155	CSX	S	2														
10/09/1997	2335	CSX	N	17		2			1		1							
10/10/1997	0027	CON	S	2														
10/10/1997	0200	CSX	S	4														
10/10/1997	0310	CSX	S	8					6		2							
10/10/1997	0350	CON	S	2														
10/10/1997	0405	CON	S	2					2									
10/10/1997	0447	CSX	S	9								7						
10/10/1997	0451	CON	N	3														
10/10/1997	0524	CON	N	6									3					
04/16/1998	0037	CON	N	12														
04/16/1998	0045	CSX	S	11					2									
04/16/1998	0101	CSX	S	7														
04/16/1998	0345	CON	S	3														
04/16/1998	0410	CON	N	1														
04/16/1998	0654	CSX	N	1														
04/16/1998	0758	CSX	N	9				3										
04/16/1998	0820	CSX	N	5					1			1						
04/16/1998	0939	CSX	N	3														
04/16/1998	1010	CSX	N	3														
04/16/1998	1032	CSX	N	3													1	
04/16/1998	1043	CON	N	5														
04/16/1998	1142	CON	S	1														
04/16/1998	1209	CSX	S	4								3						
04/16/1998	1303	CSX	S	8														
04/16/1998	1456	CSX	N	1														
04/16/1998	1527	CON	N	4								3						
04/16/1998	1527	CSX	N	12														

SOURCE: Survey conducted by MVRPC and MVEMA for Montgomery/Greene County Local Emergency Response Council.
Surveys conducted for 24-hour periods on 10/9-10/97, 4/16/98, and 7/24/98.

**APPENDIX A
FULL DATA TABLE
RAILROAD HAZ/MAT SURVEY**

DATE	TIME (Military)	TRACK	DIR	TOTAL PLACARDS	PLACARD ID (See Appendix B)													
					2968	2988	3002	3065	3077	3082	3219	3256	3257	3265	3272	3289	9259	EXPL
04/16/1998	1715	CSX	S	1														
04/16/1998	1716	CON	S	1														
04/16/1998	1833	CSX	S	16		2												
04/16/1998	2240	CSX	S	9						5		2	2					
04/16/1998	2256	CON	S	8						2								
04/16/1998	2306	CSX	N	26		1												
07/24/1998	0015	CSX	N	2														
07/24/1998	0104	CON	S	28						9							1	
07/24/1998	0155	CSX	N	13									10					
07/24/1998	0305	CSX	S	3														
07/24/1998	0312	CSX	N	2														
07/24/1998	0355	CSX	S	7						4			1					
07/24/1998	0445	CON	N	7														
07/24/1998	0508	CSX	S	19		1												
07/24/1998	0535	CSX	N	19	3													
07/24/1998	0610	CSX	N	2								1						
07/24/1998	0635	CSX	N	6														
07/24/1998	0819	CSX	S	4					1									
07/24/1998	0823	CON	N	22				2		5								
07/24/1998	0841	CSX	N	10														
07/24/1998	1237	CSX	S	5														
07/24/1998	1326	CON	S	5														
07/24/1998	1350	CON	S	2						1								
07/24/1998	1640	CON	S	7					2			2						
07/24/1998	1700	CON	N	3														
07/24/1998	1715	CON	N	4														
07/24/1998	1755	CSX	N	13														
07/24/1998	1950	CSX	S	9														
07/24/1998	2009	CON	S	6						2								
07/24/1998	2101	CSX	S	5														1

TOTAL FOR OCTOBER 1997	109	0	2	1	1	0	11	1	3	9	2	3	0	0	0
TOTAL FOR APRIL 1998	154	0	3	0	0	3	10	0	2	9	0	0	0	1	0
TOTAL FOR JULY 1998	203	3	1	0	2	3	21	0	3	11	0	0	1	0	1
TOTALS	466	3	6	1	3	6	42	1	8	29	2	3	1	1	1

Appendix B

Key To Observed Placards

HAZARDOUS MATERIALS RAILROAD SURVEY

KEY TO OBSERVED PLACARDS

These placard ID symbols or numbers are found most frequently observed. The numbers are directly from the USDOT 1996 Emergency Response Guidebook.

ID	CHEMICAL TYPE
1005	AMMONIA, anhydrous AMMONIA, anhydrous, liquefied AMMONIA SOLUTION, with more than 50% ammonia ANHYDROUS AMMONIA ANHYDROUS AMMONIA, liquefied
1010	BUTADIENES, inhibited
1014	CARBON DIOXIDE AND OXYGEN MIXTURE CARBON DIOXIDE AND OXYGEN MIXTURE, compressed OXYGEN AND CARBON DIOXIDE MIXTURE OXYGEN AND CARBON DIOXIDE MIXTURE, compressed
1017	CHLORINE
1038	ETHYLENE, refrigerated liquid (cryogenic liquid)
1041	CARBON DIOXIDE AND ETHYLENE OXIDE MIXTURE, with more than 9% but not more than 87% ethylene oxide CARBON DIOXIDE AND ETHYLENE OXIDE MIXTURE, with more than 6% ethylene oxide ETHYLENE OXIDE AND CARBON DIOXIDE MIXTURES, with more than 9% but not more than 87% ethylene oxide ETHYLENE OXIDE AND CARBON DIOXIDE MIXTURES, with more than 6% ethylene oxide
1050	HYDROGEN CHLORIDE, anhydrous
1063	METHYL CHLORIDE REFRIGERANT GAS R-40
1075	BUTANE BUTANE MIXTURE BUTYLENE ISOBUTANE ISOBUTANE MIXTURE ISOBUTYLENE LIQUEFIED PETROLEUM GAS LPG PETROLEUM GASES, liquefied PROPANE PROPANE MIXTURE PROPYLENE

ID	CHEMICAL TYPE
1079	SULFUR DIOXIDE SULFUR DIOXIDE, liquefied SULPHUR DIOXIDE SULPHUR DIOXIDE, liquefied
1090	ACETONE
1093	ACRYLONITRILE, inhibited
1114	BENZENE
1131	CARBON BISULFIDE CARBON BISULPHIDE CARBON DISULFIDE CARBON DISULPHIDE
1193	ETHYL METHYL KETONE METHYL ETHYL KETONE
1203	GASOHOL GASOLINE MOTOR SPIRIT PETROL
1210	INK, printer's, flammable PRINTING INK, flammable
1218	ISOPRENE, inhibited
1219	ISOPROPANOL ISOPROPYL ALCOHOL
1235	METHYLAMINE, aqueous solution
1242	METHYLDICHLOROSILANE
1250	METHYLTRICHLOROSILANE
1256	NAPHTHA, solvent
1268	PETROLEUM DISTILLATES, n.o.s. PETROLEUM PRODUCTS, n.o.s.
1276	n-PROPYL ACETATE
1294	TOLUENE
1298	TRIMETHYLCHLOROSILANE
1307	XYLENES

Source: USDOT 1996 Emergency Response Guidebook.

ID	CHEMICAL TYPE
1382	POTASSIUM SULFIDE, anhydrous POTASSIUM SULFIDE, with less than 30% of water crystallization POTASSIUM SULFIDE, with less than 30% water of hydration POTASSIUM SULPHIDE, anhydrous POTASSIUM SULPHIDE, with less than 30% of water crystallization POTASSIUM SULPHIDE, with less than 30% water of hydration
1495	SODIUM CHLORATE
1719	ALKALINE LIQUID, n.o.s. CAUSTIC ALKALI LIQUID, n.o.s.
1760	ACID, liquid, n.o.s. ALUMINUM PHOSPHATE, solution ALUMINUM SULFATE, solution ALUMINUM SULPHATE, solution 2-(2-AMINOETHOXY)ETHANOL AMINOPROPYLDIETHANOLAMINE N-AMINOPROPYLMORPHOLINE CHEMICAL KIT COMPOUND, rust preventing (corrosive) COMPOUND, rust removing (corrosive) COMPOUND, tree or weed killing, liquid (corrosive) COMPOUND, vulcanizing, liquid (corrosive) COMPOUND, cleaning, liquid (corrosive) CORROSIVE LIQUID, n.o.s. COSMETICS, liquid, n.o.s. 2,2-DICHLOROPROPIONIC ACID DRUGS, liquid, n.o.s. FERROUS CHLORIDE, solution FLAME RETARDANT COMPOUND, liquid (corrosive) HEXANOIC ACID ISOPENTANOIC ACID MEDECINES, corrosive, liquid, n.o.s. MORPHOLINE, aqueous mixture NITRIC ACID, 40% or less ORM-B, n.o.s. PAINT (corrosive) PAINT RELATED MATERIAL (corrosive) TEXTILE TREATING COMPOUND OR MIXTURE, liquid (corrosive) TITANIUM SULFATE, solution TITANIUM SULPHATE, solution
1778	FLUOROSILICIC ACID FLUOSILICIC ACID HYDROFLUOROSILICIC ACID HYDROFLUOSILICIC ACID
1782	HEXAFLUOROPHOSPHORIC ACID

ID	CHEMICAL TYPE
1789	COMPOUND, cleaning liquid (containing hydrochloric [muriatic] acid) HYDROCHLORIC ACID HYDROCHLORIC ACID, mixture HYDROCHLORIC ACID, solution MURATIC ACID
1814	CAUSTIC POTASH, liquid CAUSTIC POTASH, solution POTASSIUM HYDROXIDE, solution
1824	CAUSTIC SODA, solution SODIUM HYDROXIDE, solution
1830	SULFURIC ACID SULFURIC ACID, with more than 51% acid SULPHURIC ACID SULPHURIC ACID, with more than 51% acid
1942	AMMONIUM NITRATE, with not more than 0.2% combustible substances AMMONIUM NITRATE, with organic coating
1951	ARGON, refrigerated liquid (cryogenic liquid)
1987	ALCOHOLS, n.o.s. DENATURED ALCOHOL
1993	COMBUSTIBLE LIQUID, n.o.s. COMPOUND, tree or weed killing, liquid (flammable) COMPOUNDS, cleaning, liquid (flammable) COSMETICS, n.o.s. CREOSOTE, coal tar DIESEL FUEL DISINFECTANT, liquid, n.o.s. DRUGS, n.o.s. ETHYL NITRATE FLAMMABLE LIQUID, n.o.s. FUEL OIL HEATER OR REFRIGERATOR CAR, liquid fuel type MEDICINES, flammable, liquid, n.o.s. REFRIGERATING MACHINE
2014	HYDROGEN PEROXIDE, aqueous solution, with not less than 20% but not more than 60% hydrogen peroxide (stabilized as necessary)
2015	HYDROGEN PEROXIDE, aqueous solution, stabilized, with more than 60% hydrogen peroxide
2046	CYMENES
2051	2-DIMETHYLAMINOETHANOL DIMETHYLETHANOLAMINE

ID	CHEMICAL TYPE
2055	STYRENE MONOMER, inhibited
2074	ACRYLAMIDE
2187	CARBON DIOXIDE, refrigerated liquid
2198	PHOPHOROUS PENTAFLUORIDE PHOPHOROUS PENTAFLUORIDE, compressed
2348	BUTYL ACRYLATE BUTYL ACRYLATES, inhibited
2448	SULFUR, molten SULPHUR, molten
2582	FERRIC CHLORIDE, solution
2664	DIBROMOMETHANE
2810	COMPOUND, tree or weed killing, liquid (toxic) DRUGS, liquid, n.o.s. MEDICINES, poisonous, liquid, n.o.s. MEDICINES, toxic, liquid, n.o.s. POISON B, liquid, n.o.s. POISONOUS LIQUID, n.o.s. POISONOUS LIQUID, n.o.s. (Inhalation Hazard Zone A) POISONOUS LIQUID, (Inhalation Hazard Zone B) POISONOUS LIQUID, organic, n.o.s. POISONOUS LIQUID, organic, n.o.s. (Inhalation Hazard Zone A) POISONOUS LIQUID, organic, n.o.s. (Inhalation Hazard Zone B) TOXIC LIQUID, n.o.s. TOXIC LIQUID, n.o.s. (Inhalation Hazard Zone A) TOXIC LIQUID, (Inhalation Hazard Zone B) TOXIC LIQUID, organic, n.o.s. TOXIC LIQUID, organic, n.o.s. (Inhalation Hazard Zone A) TOXIC LIQUID, organic, n.o.s. (Inhalation Hazard Zone B)
2968	MANEB, stabilized MANEB PREPARATION, stabilized
2988	CHLOROSILANES, n.o.s. CHLOROSILANES, water-reactive, flammable, corrosive, n.o.s.
3002	PHENYL UREA PESTICIDE, liquid, poisonous PHENYL UREA PESTICIDE, liquid, toxic
3065	ALCOHOLIC BEVERAGES
3077	ENVIRONMENTALLY HAZARDOUS SUBSTANCES, solid, n.o.s. HAZARDOUS WASTE, solid, n.o.s.

3082	OTHER REGULATED SUBSTANCES, solid, n.o.s. ENVIRONMENTALLY HAZARDOUS MATERIAL, liquid, n.o.s. HAZARDOUS WASTE, liquid, n.o.s. OTHER REGULATED SUBSTANCES, liquid, n.o.s.
3219	NITRITES, inorganic, aqueous solution, n.o.s.
3256	ELEVATED TEMPERATURE LIQUID, flammable, n.o.s., with flash point above 37.8°C (100°F), at or above its flash point ELEVATED TEMPERATURE LIQUID, flammable, n.o.s., with flash point above 60.5°C (141°F), at or above its flash point
3257	ELEVATED TEMPERATURE LIQUID, n.o.s., at or above 100° C (212°F) and below its flash point ELEVATED TEMPERATURE LIQUID, n.o.s., at or above 240° C (464°F) and below its flash point
3265	CORROSIVE LIQUID, acidic, organic, n.o.s.
3272	ESTERS, n.o.s.
3289	POISONOUS LIQUID, corrosive, inorganic, n.o.s. POISONOUS LIQUID, corrosive, inorganic, n.o.s. (Inhalation Hazard Zone A) POISONOUS LIQUID, corrosive, inorganic, n.o.s. (Inhalation Hazard Zone B) TOXIC LIQUID, corrosive, inorganic, n.o.s. TOXIC LIQUID, corrosive, inorganic, n.o.s. (Inhalation Hazard Zone A) TOXIC LIQUID, corrosive, inorganic, n.o.s. (Inhalation Hazard Zone B)
9259	ELEVATED TEMPERATURE MATERIAL, liquid, n.o.s., (at or above 100°C (212°F) and below its flash point
EXPL*	EXPLOSIVES

*Not an official placard marking - used to describe EXPLOSIVES placard. (see USDOT Guide Book)